

Description

TD62 is a medium capacity thermodynamic steam trap. These horizontal /vertical traps are easy to maintain. This steam trap is designed with replaceable seat and internal strainer.

Material

NO	Part	Material
1	Body	ASTM A217 Gr.WC6
2	Cover	ASTM A217 Gr.WC6
3	Strainer cap	ASTM A217 Gr.WC6
4	Strainer screen	Stainless steel
5	Disc	Stainless steel
6	Seat	Stainless steel
7	Cover studs (top)	ASTM A193 Gr.B16
7A	Cover studs (bottom)	ASTM A193 Gr.B16
8	Cover studs (top)	ASTM A194 Gr.8M
9	Cover gasket	Spirally wound
10	Name plate	Stainless steel

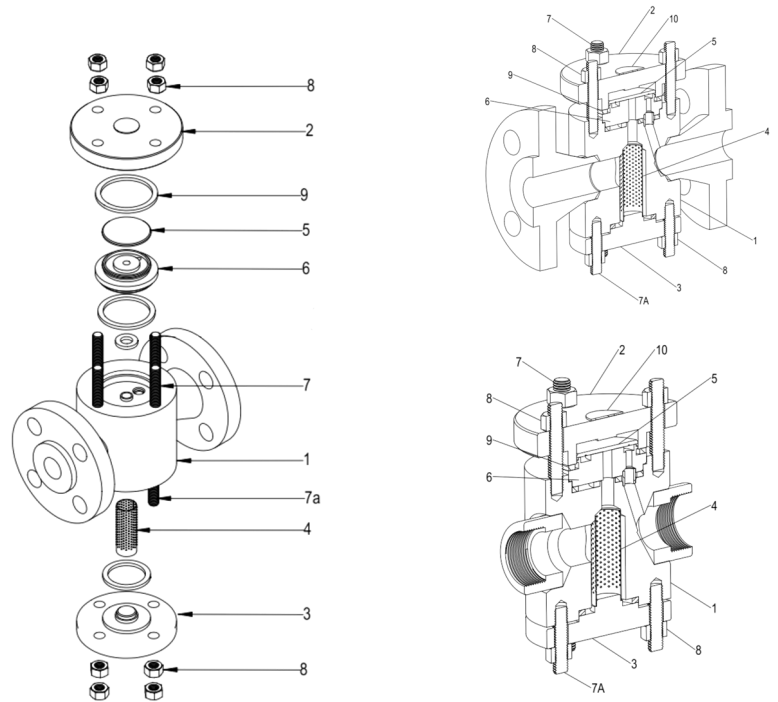

Dimensions / weights

(approximate) in mm and kg

Size	1"	3/4"	1"
A	88	88	88
B	#300	180	185
	#600	190	192
C	120	123	133
D	72	72	72
E	40	40	40
F	30	30	30
Weight	Screwed	7	7
	#300	8.5	9.5
	#600	8.8	10

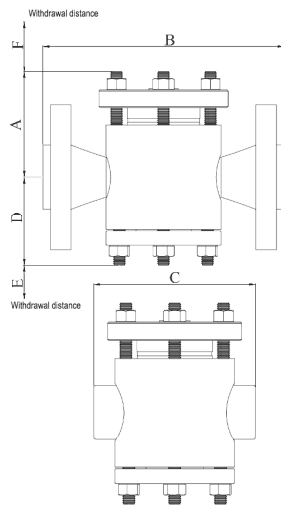

Pressure / temperature limits

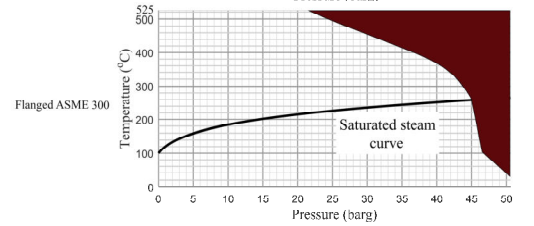
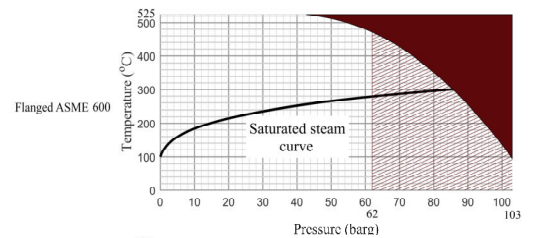

The product should not be used in this region as damage to the internals may occur.
 The product must not be used in this region

Capacity

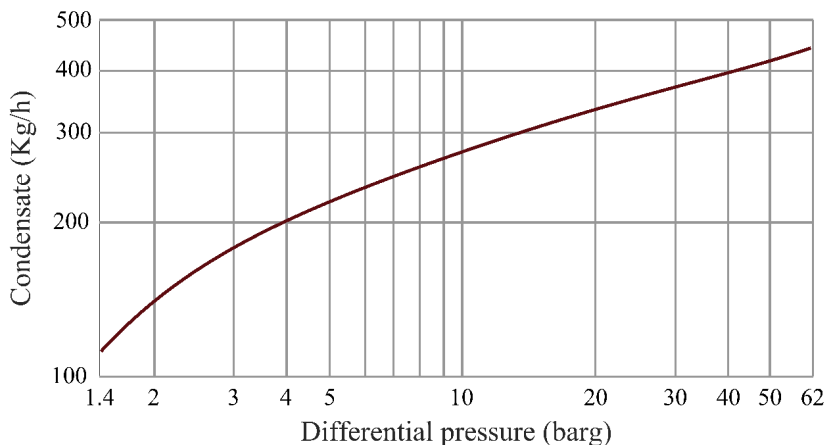

Body design conditions	ANSI600
PMA (Max. allowable pressure)	103barg@93°C
TMA (Max. allowable temp.)	525°C@42.7barg
Max. cold hydraulic test pressure	155 barg

Available spares

- Disc and seat
- Strainer screen
- Gaskets