

### *jet mixer*

Jet mixers are used to mix and circulate liquids in tanks. Similar to jet pumps, motive nozzle converts pressure energy to kinetic energy. Increasing the velocity of motive stream at nozzle generates low pressure where the surrounding fluid is sucked in. finally the mixture leaves the jet mixer and mixes more with fluid in the tank. The viscosity of the circulation fluid must not be too high.

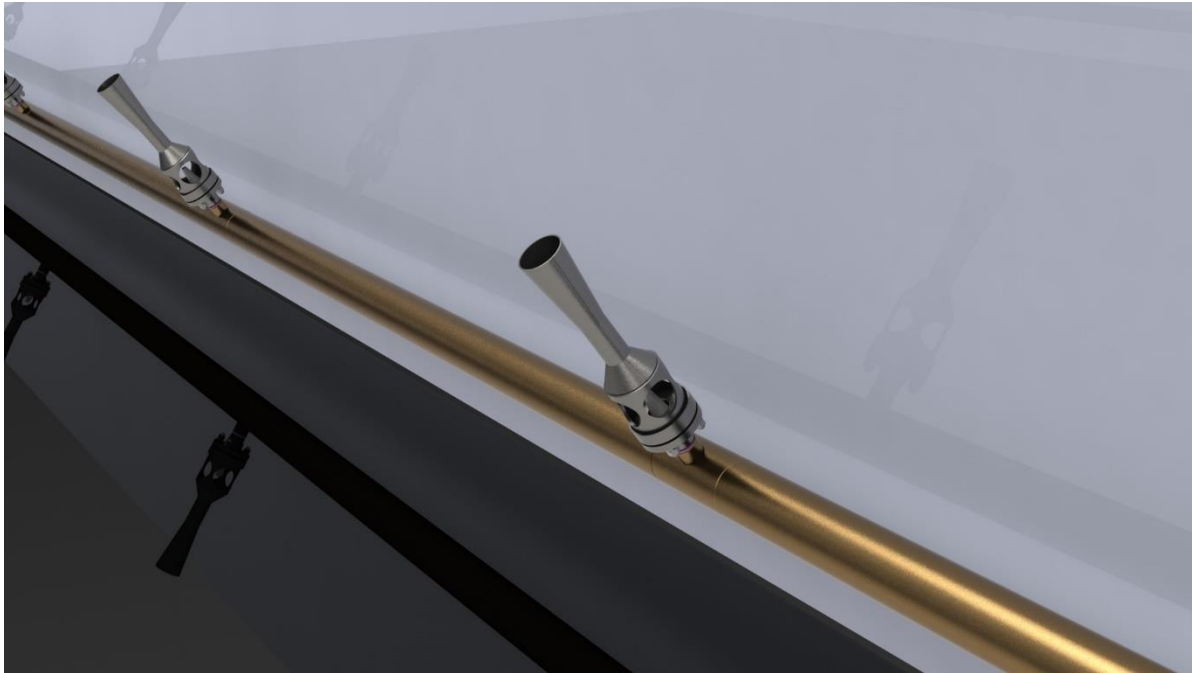

<u>General Usage</u>	<u>Typical Applications in Industries</u>
Jet nozzle entrains a large volume of liquid, using a small amount of pumped fluid and produces high mixing rates and strong movement using small amount of energy.	<ul style="list-style-type: none"> <li>❖ Mainly used in <u>vessels, storage tanks and neutralization basins</u></li> <li>❖ A wide variety of wastewater applications including <u>flow equalization basins, CSO tanks, anaerobic digesters, SBRs, oxidation ditches and flash mix tanks</u></li> <li>❖ Neutralisation mixing duties using Phosphoric, Hydrochloric and Sulphuric acids on <u>Water treatment</u></li> <li>❖ Blending of Lube oils on <u>Petroleum plant</u></li> <li>❖ Homogenisation of epoxy liquid in <u>Paint production, Mixing of Food products</u></li> <li>❖ Blending effluent containing Glycol <u>on Pharmaceutical process</u></li> </ul>

<u>Advantages</u>	<ul style="list-style-type: none"> <li>❖ No moving parts</li> <li>❖ Low maintenance cost</li> <li>❖ Simple, safe and reliable operation</li> <li>❖ Quickly and easily put into operation</li> <li>❖ Hardly subject to any wear</li> <li>❖ Long lifetime</li> </ul>
-------------------	--

<u>Applicable Materials</u>	<ul style="list-style-type: none"> <li>❖ Stainless Steel</li> <li>❖ Carbon Steel</li> <li>❖ Hastelloy</li> <li>❖ Polypropylene</li> </ul>
-----------------------------	---

<u>Design Codes/ Standards</u>	<u>Quality Assurance</u>
<ul style="list-style-type: none"> <li>❖ ASME Sec.VIII</li> <li>❖ ASME B.31.1</li> <li>❖ ASME B.31.3</li> </ul>	

<u>Karajet jet mixer Advantages:</u>	<ul style="list-style-type: none"> <li>❖ Custom design</li> <li>❖ Manufactured from various materials proportional to corrosive medium or environment</li> </ul>
--------------------------------------	--

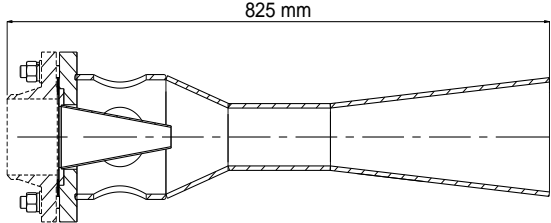
Specifications of one Type			
Item	Storage Tank (10-TK-904) Jet Mixer		
Project	Ilam Olefin Plant		
Purchaser	PIDMCO		
Fluid name	-	Fuel Oil	
Motive Pressure	barg	1.4 / 2.47 / 3.51	
Motive Flow Rate (min. / norm. / max)	Kg/hr	10 / 27 / 40	
Working Volume	m3	919	

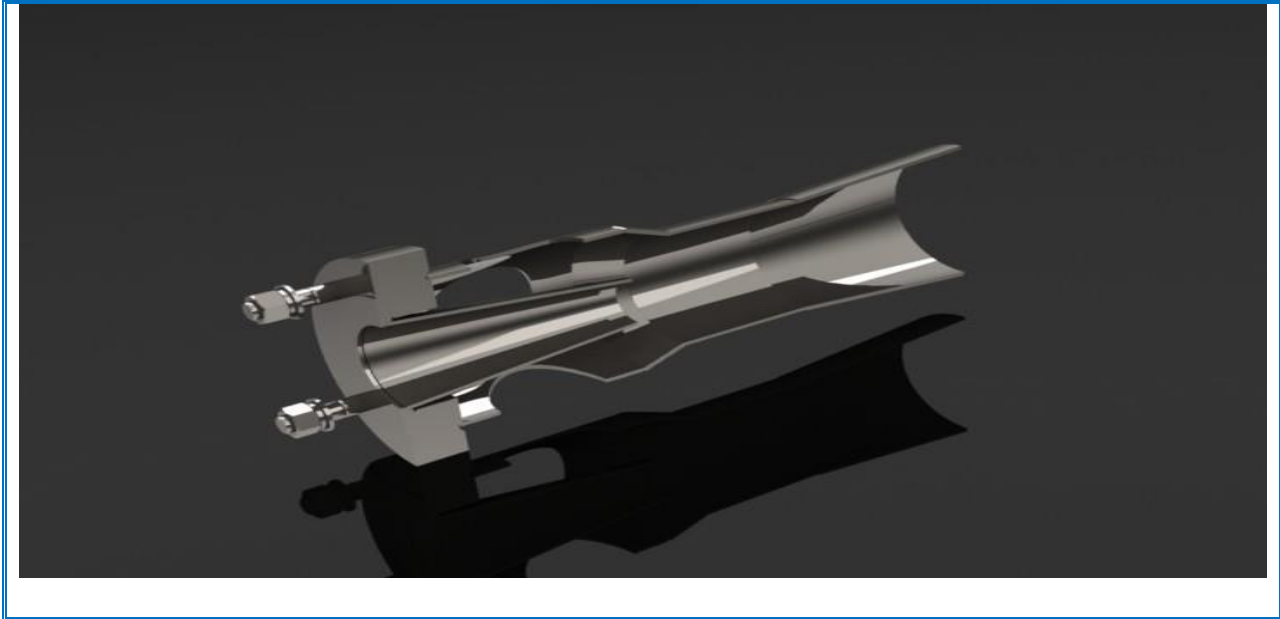

[Previous Projects](#)

[Equipment photos / Operation photos / Applications photos](#)